



Performance Study of New Pixel Hybrid Photon Detector Prototypes for the LHCb RICH counters

Matthias Moritz

(on behalf of the LHCb Pixel Group)



- **Detector description**
- **Performance tests**
- **Summary**



The 40 MHz LHCb Pixel HPD

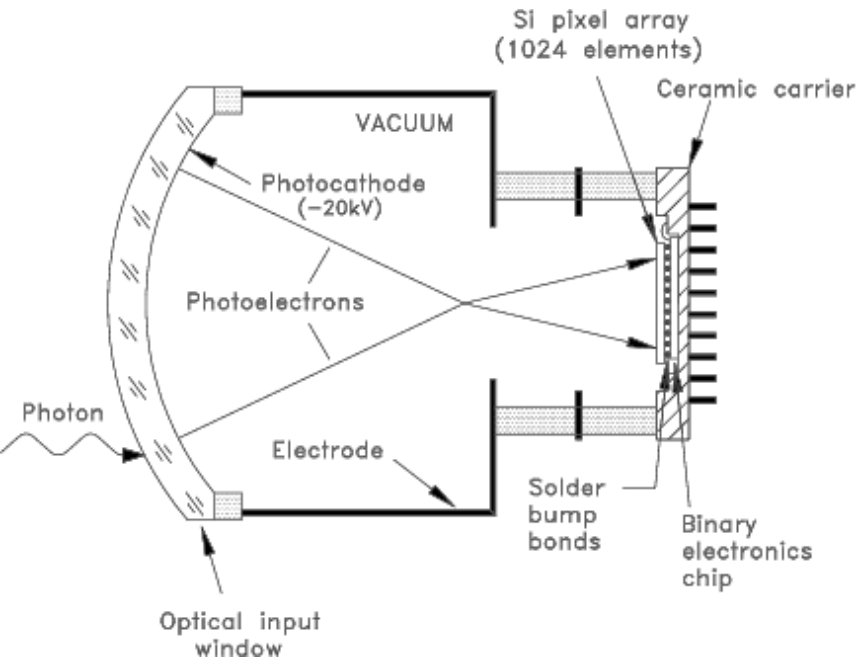

- developed as photon detector for the LHCb RICH
 - high active-total area ratio (70%)
 - high time resolution (<25ns)

- 16x16mm² Si detector bump bonded to 40 MHz binary readout chip
- encapsulated in a vacuum envelope
- cross focusing, demagnifying (x5)
 - picture granularity: 2.5x2.5mm²



Performance Tests

Real pixel size $62.5 \times 500 \mu\text{m}^2$:
 $1024 \rightarrow 8192$ pixels

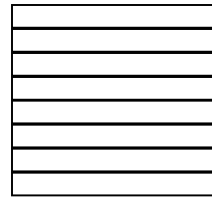

each LHCb pixel
subdivided into 8,
'OR'ed together by
readout chip

- two 40 MHz HPD prototypes tested
with **98.5% and 95.6%** working bonds (out of 8192)
(one 10 MHz HPD prototype with **>99.9%** working bonds)

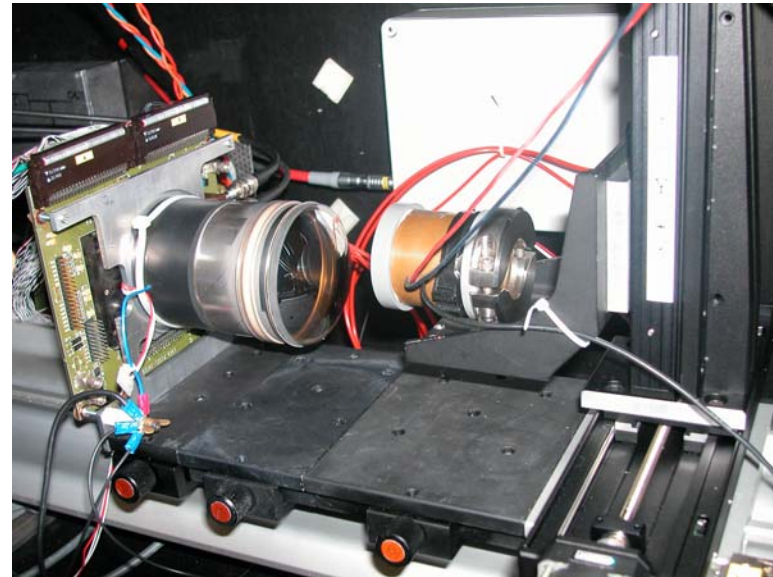
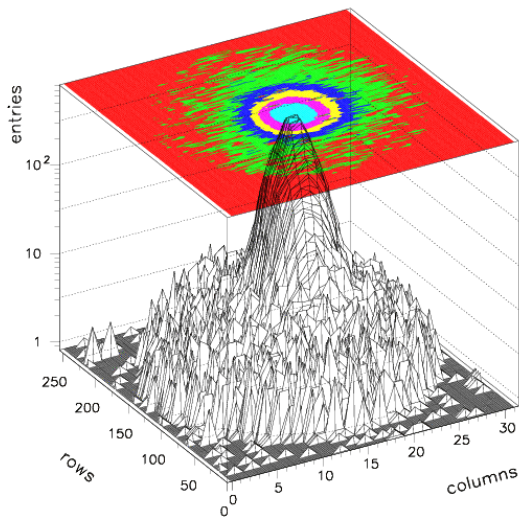

fast, pulsed LED used as light source & some test beam data

Discrimination Threshold

Analogue front end consists of:
charge preamplifier, shaper and discriminator

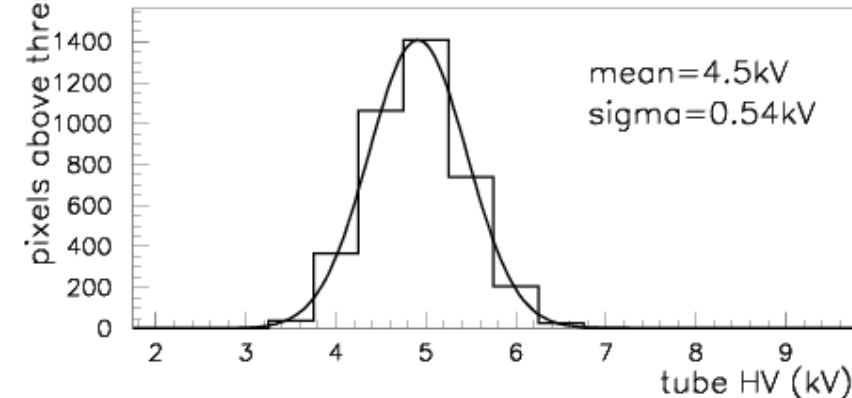
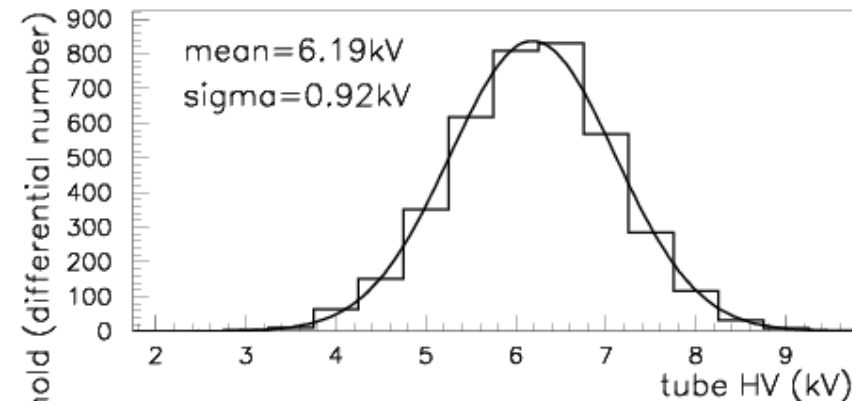

- **discriminating threshold can be adjusted**
- **threshold ($\sim 1700e^-$) and its spread ($\sim 250e^-$) within specifications**
- **3 bit pixel adjustment to achieve lower and narrower threshold distribution**
- **efficiency improvement at 20kV: $\sim 1\%$**

Detector Bias & Tube High Voltage

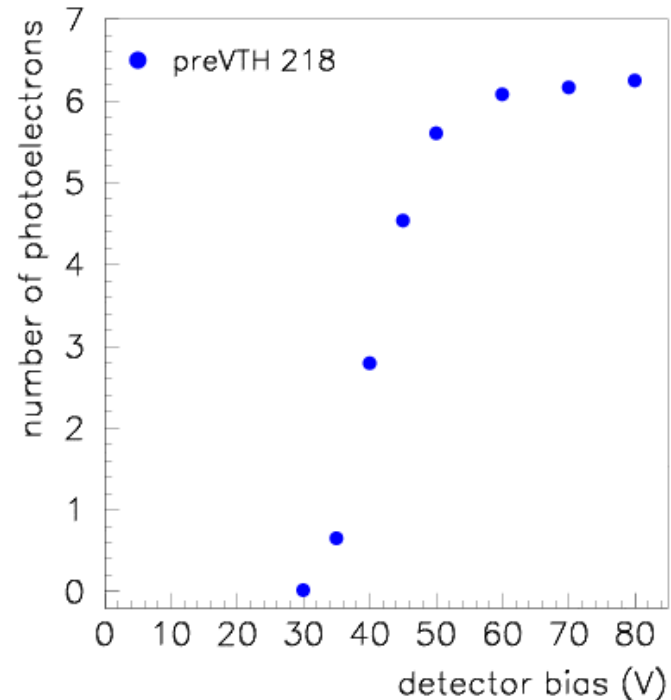
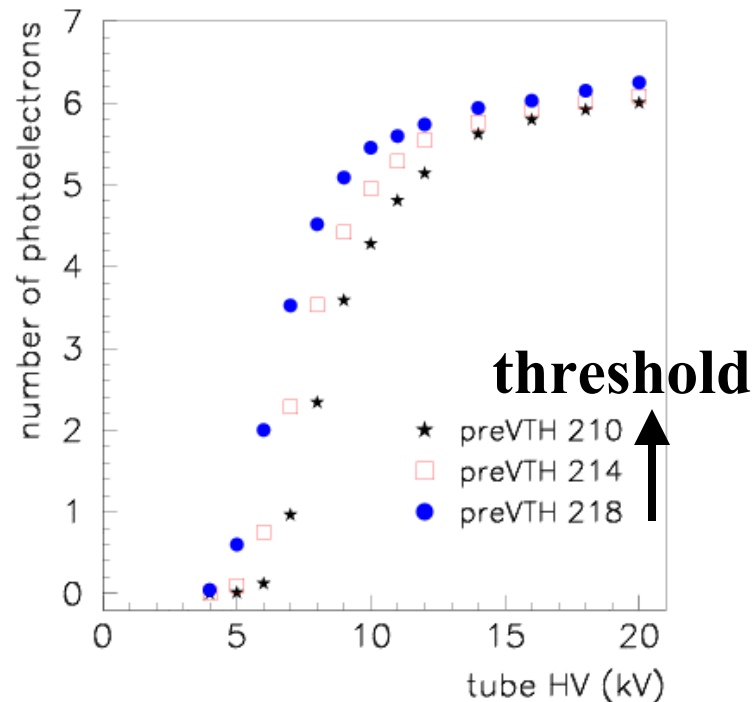

• **Performance vs. tube HV and detector bias studied**

➤ **detector has to be over-depleted to collect the charge efficiently**

Detection Efficiency

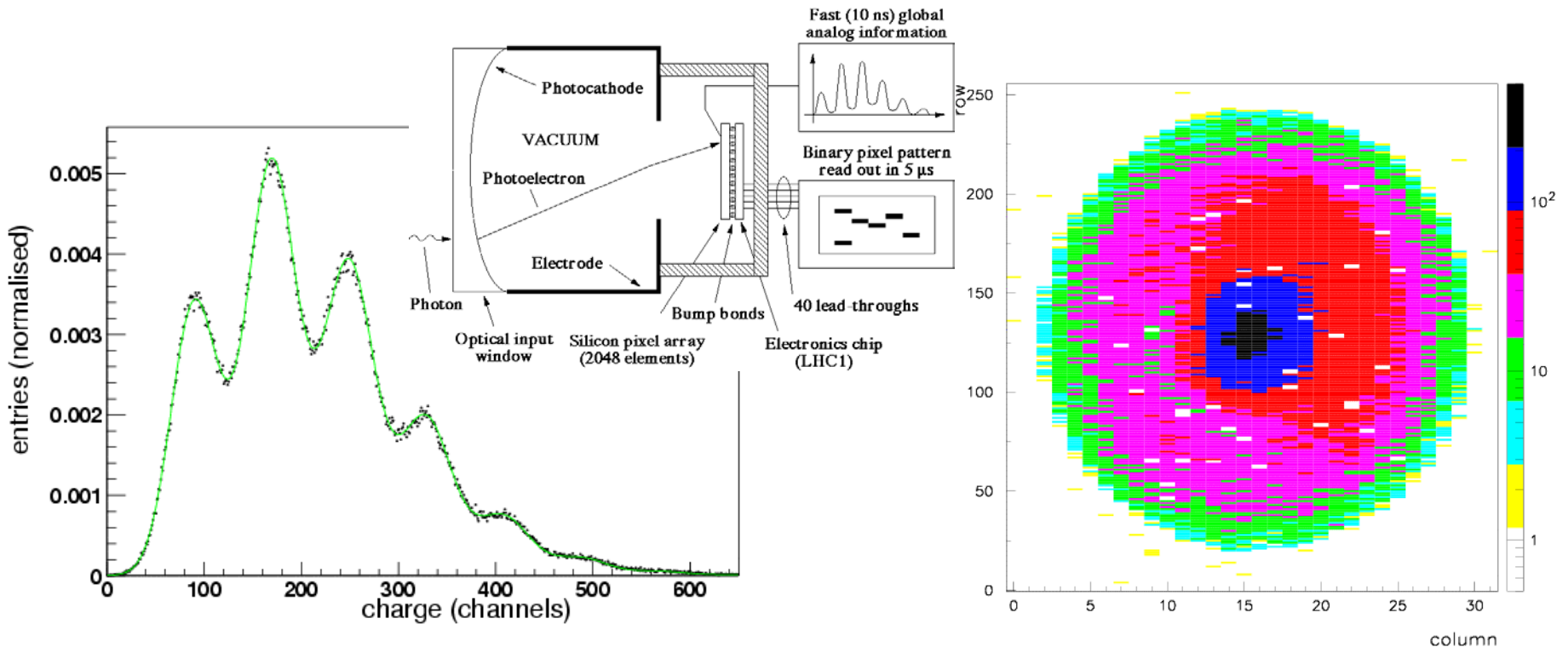

- **analogue back-pulse** signal used for **calibration**
- (only accessible in prototype tests)
- **4 parameter fit** to describe the spectrum
- to be compared with binary pixel data

Detection Efficiency Results

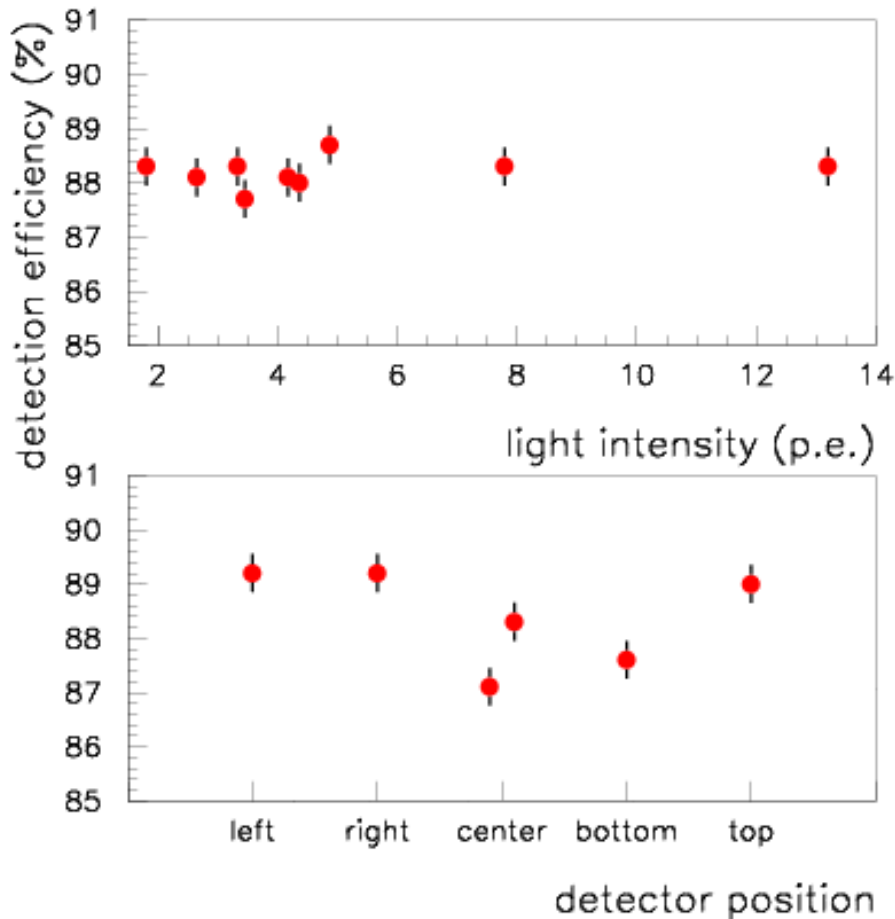

- corrections to the binary data:
 - **pixel clustering (charge sharing)** adjacent fired pixels are clustered together, assumed to originate from only one p.e.
 - **pixel clustering over-correction** account for probability to have adjacent hits (function of light intensity and light profile)
 - **missing bump bonds**
- backpulse uncertainties not incl.

➤ **stable photoelectron detection efficiency: ~88%**

Dark Counts and Ion Feed Back

dark counts:

- thermal electron emission from photo cathode produces background signal
- **average rate: $\sim 1\text{kHz}/\text{cm}^2$** (depends on temperature and other experimental conditions)

ion feed back (=afterpulses in PMTs):

- ionized residual gas molecules hitting the cathode produce a cloud of photoelectrons
 - delayed ($\sim 220\text{ns}$) signal on one or (usually) more pixels
- **average rate: $< 1\%$** (depends on tube vacuum)

background comparable to multialkali PMTs

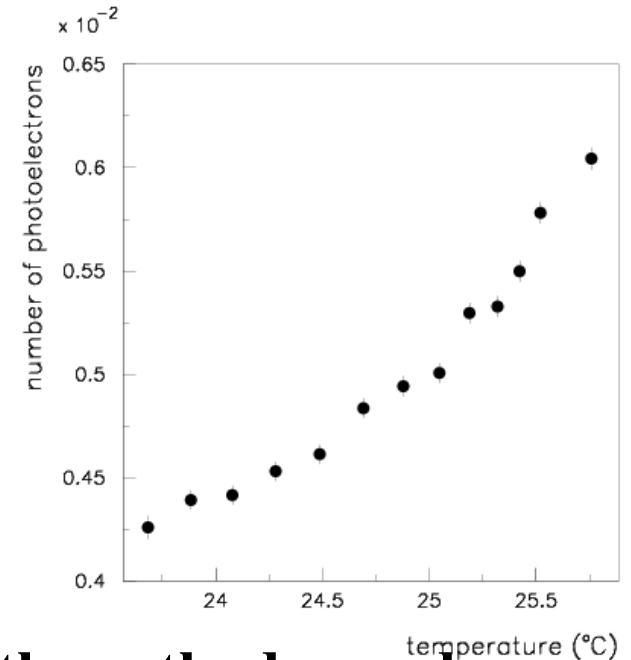

High Occupancy and Aging

chip operated in **LHCb mode**: reduce 8192 channels to **1024**
pulsed LED pulsed and DC LED only DC (~1% occup.)

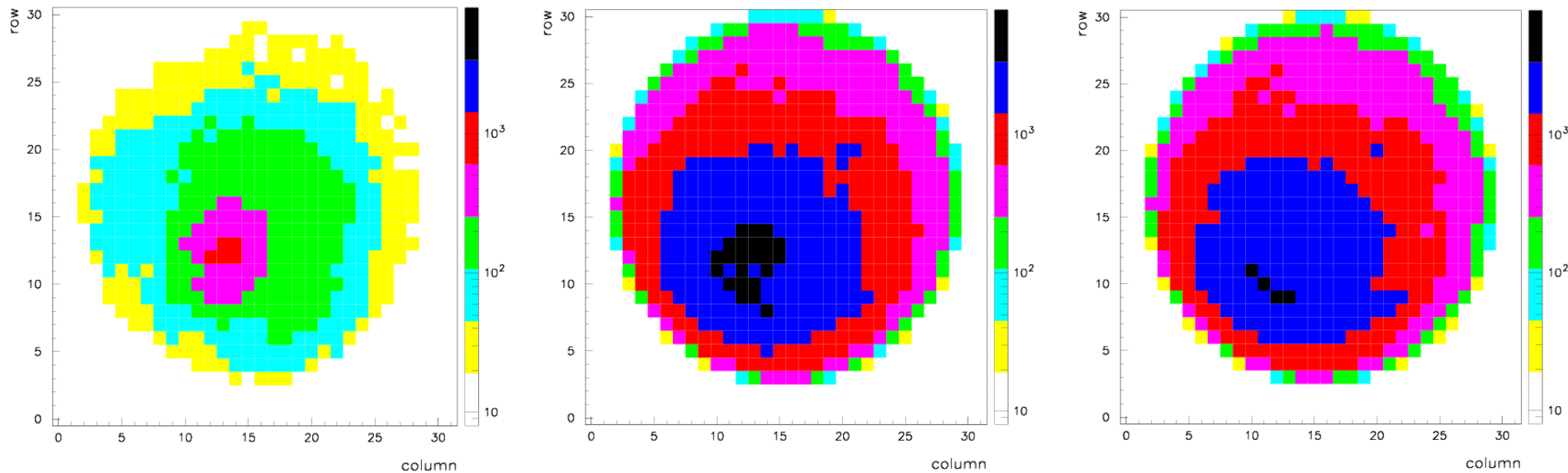

- **no efficiency loss** due to DC LED background signal
- **aging test**: simulate light exposure of 10 years LHC operation at 1% pixel occupancy: **no efficiency (DE and QE) loss** observed

Test-beam Measurements

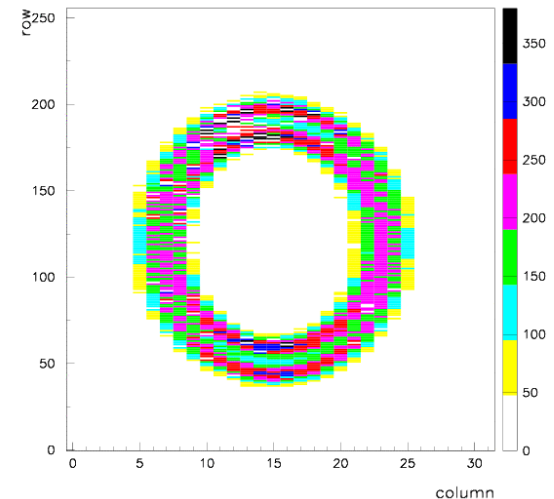
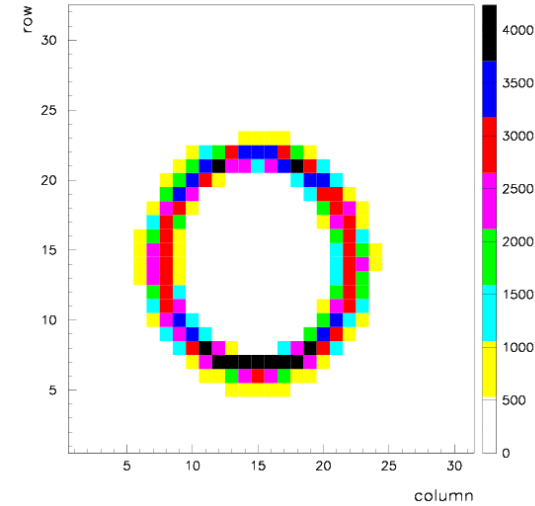
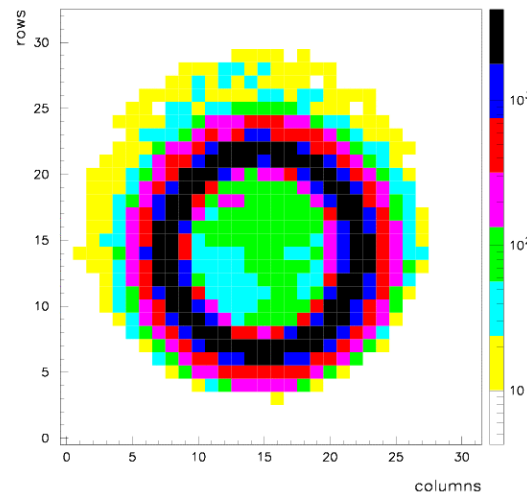
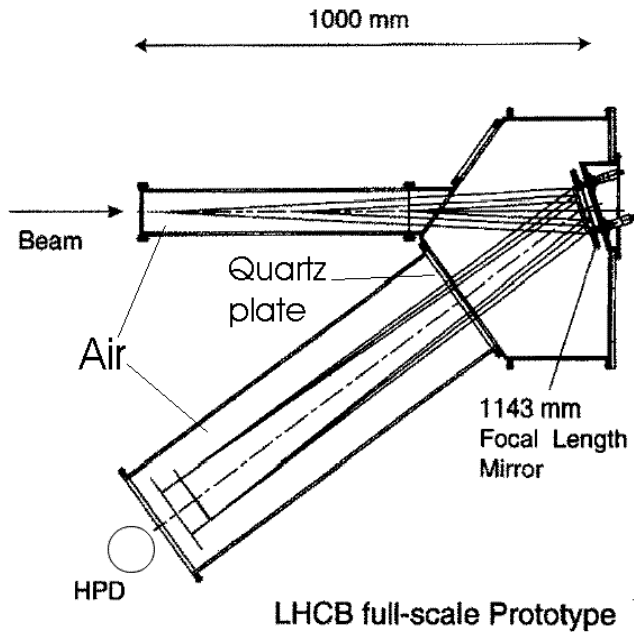

- 10 GeV pions/electrons traversing through air
- Cherenkov rings focused on HPD
- all tests in agreement with LED results!

Summary

Performance of two fully **operational and functional 40MHz LHCb pixel HPDs** studied:

- **discriminating threshold ($\sim 1700e^-$) and its spread ($\sim 250e^-$) within specifications**
- **efficiency improvement with threshold adjustment demonstrated**
- **photoelectron detection efficiency stable ($\sim 88\%$) and above specification**
- **background due to dark counts and ion feed back small**
- **no performance degradation observed in operation with high pixel occupancy and after aging tests**